



Battery Guard

To ensure that the vehicle will start

Background

In many vehicles the battery is used, when the vehicle is not in use, for couplings other than those that are normally assembled. This means that the battery is often discharged and the vehicle cannot be started. In order to avoid this, SEPAB has introduced a battery guard to ensure that the vehicle will always start.

What?

SEPAB's battery guard is an electronic guard which cuts off the extra couplings when the battery nears its limit for being able to start the vehicle.

How?

Our battery guard is based on Mos-Fet technology and is suitable when you are trying to use as little no-load current as possible and so as not to disturb sensitive electronics in the vehicle. With its minimum current load of a few micro-amperes, the battery guard will itself turn the battery to standby, which otherwise is done with the traditional relay-based battery guard.

Characteristics

- Microprocessor-controlled in order to achieve precision in working and standby modes
- The output threshold is up to 3A without an extra relay or power switch.
- Two working currents are possible (chosen via a ring).
- Minimal no-load current
- Provided with work delay which allows large intermittent current de-powering (e.g. when starting a rear box lift etc.).
- Provided with a 9-pole wash-proof contact piece for simple installation.
- Molded electronics in order to withstand engine room environments.
- EMC-shielded (provide with an EMI-filter on the control current output).
- Suitable for combining with our PowerSwitch programme for system constructions.



Article number:	
6BV123	12 Volt
6VB243	24 Volt
Technical data 6BV123	
Operating current:	12 Volt
Standby mode voltage:	11.75/11.4 Volt
Working mode voltage:	12.3 Volt
Technical data 6BV243	
Operating current:	24 Volt
Standby mode voltage:	23.5/23.0 Volt
Working mode voltage:	24.5 Volt

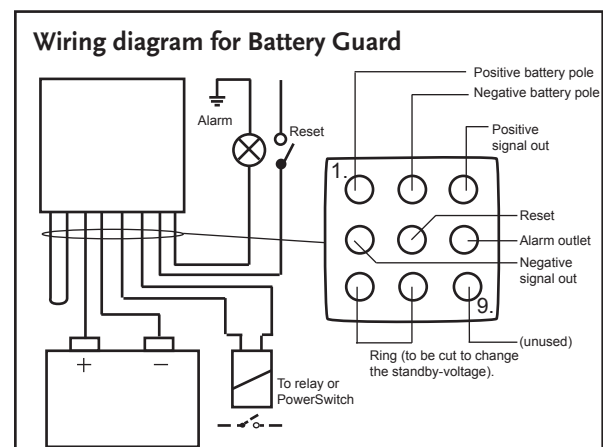

No mission is impossible. sepab.se